

36-37: Luftqualitätssensor 1 oder Raumtemp. Sensor (Temperaturausgang A2 von KWL FTF)  
38-39: Luftqualitätssensor 2  
40-41: Luftqualitätssensor 3

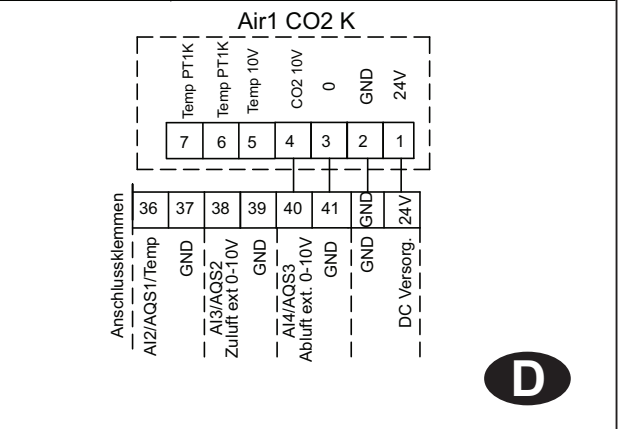

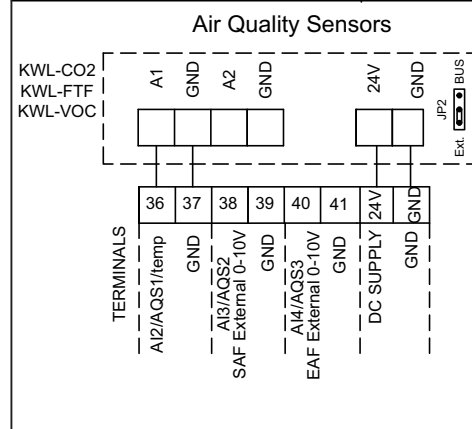
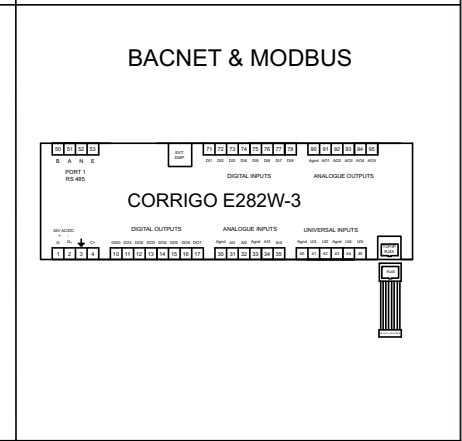
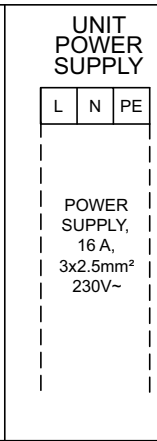
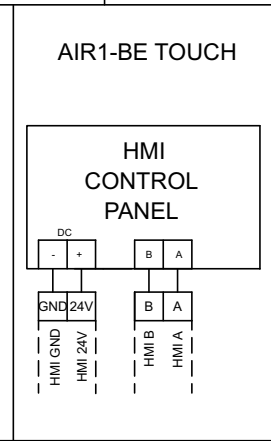
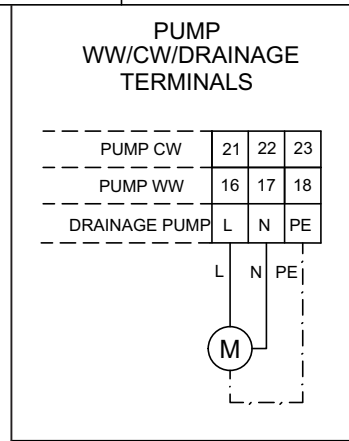
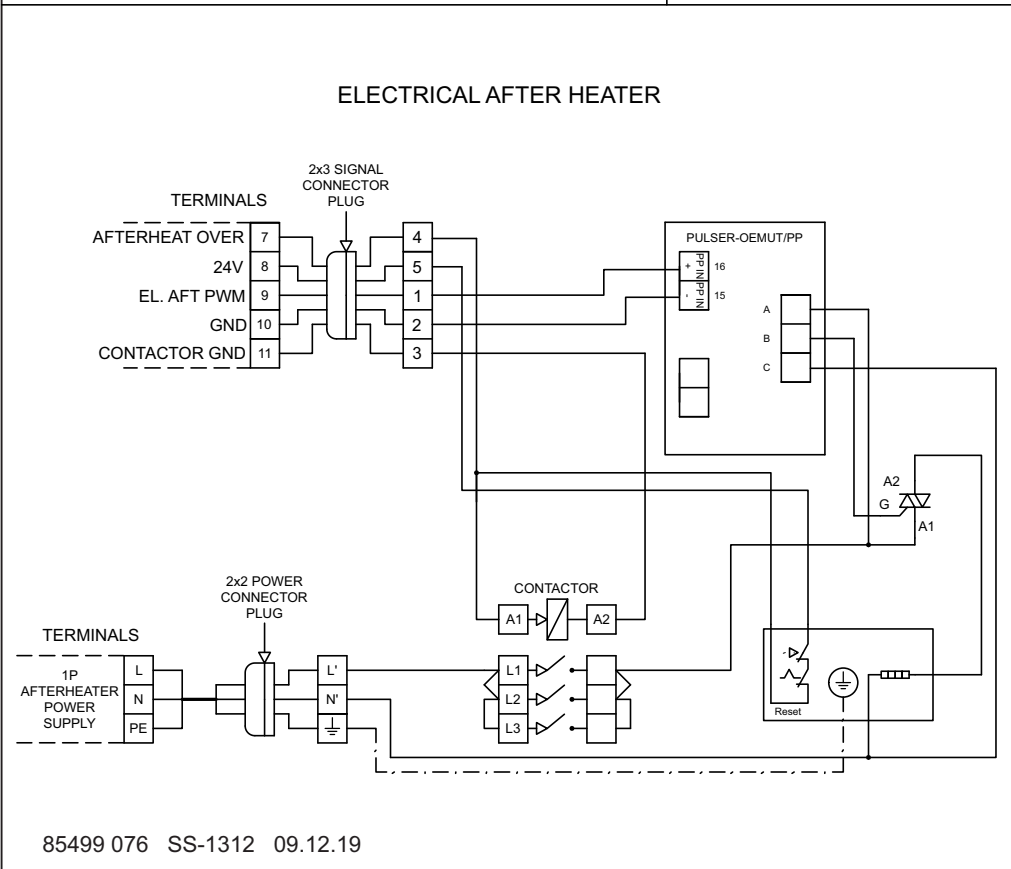
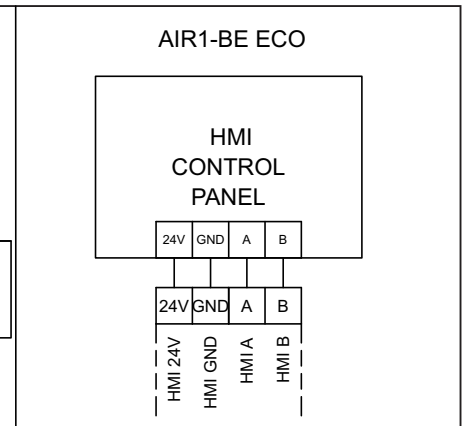
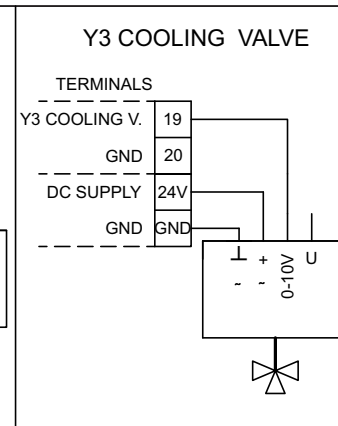
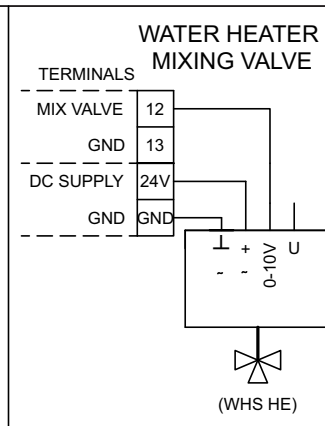
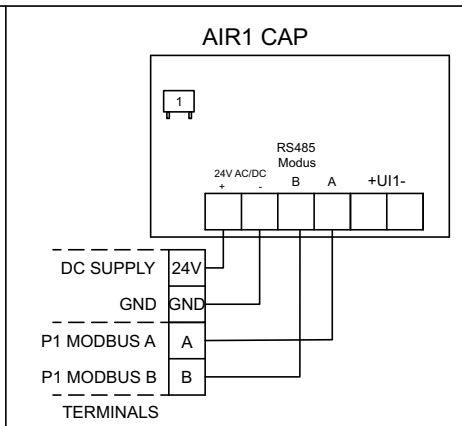
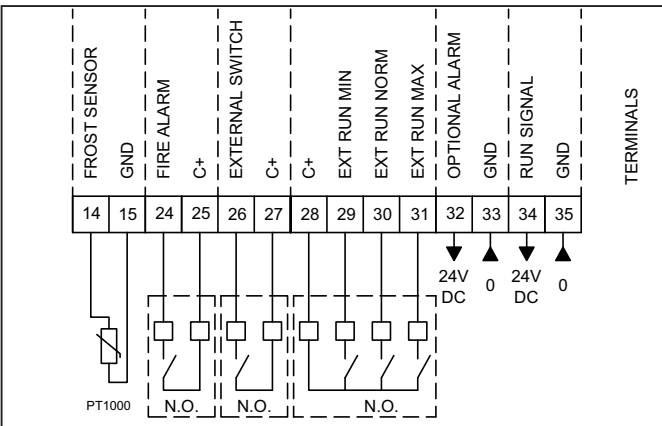

36-37: Air Quality Sensor 1 or room temp sensor (temp output A2 of KWL FTF)

38-39: Air Quality Sensor 2

40-41: Air Quality Sensor 3

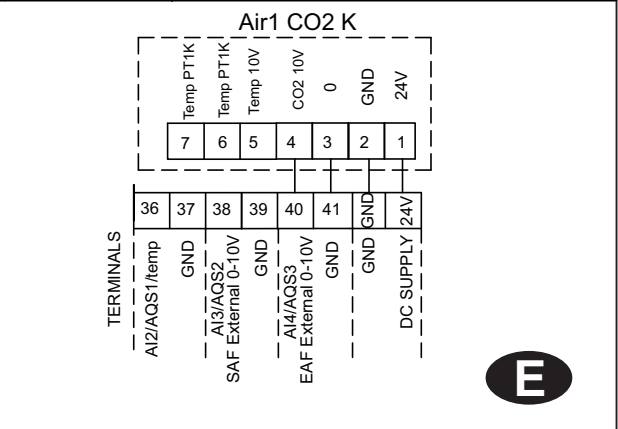

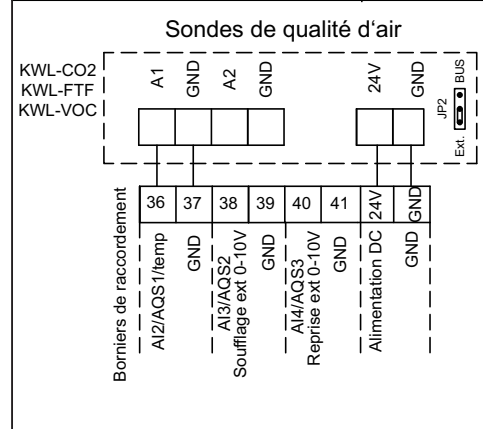
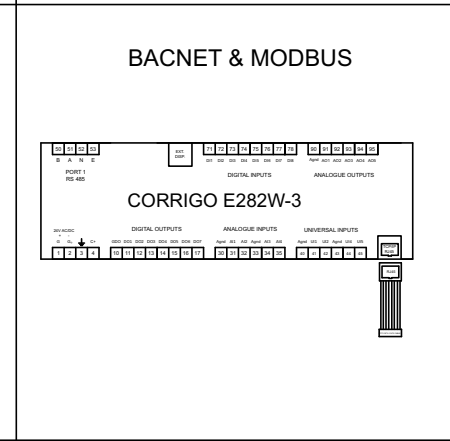
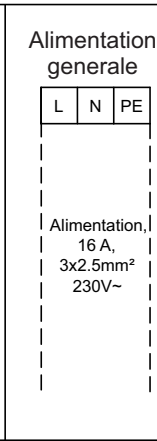
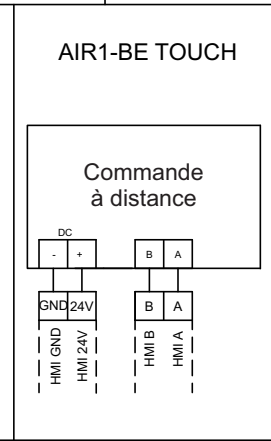
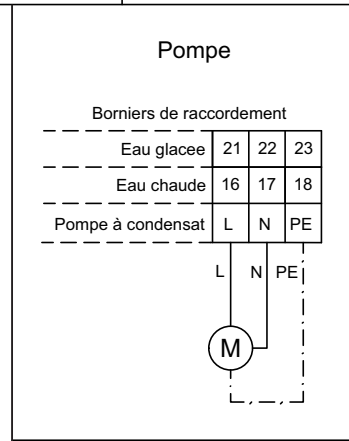
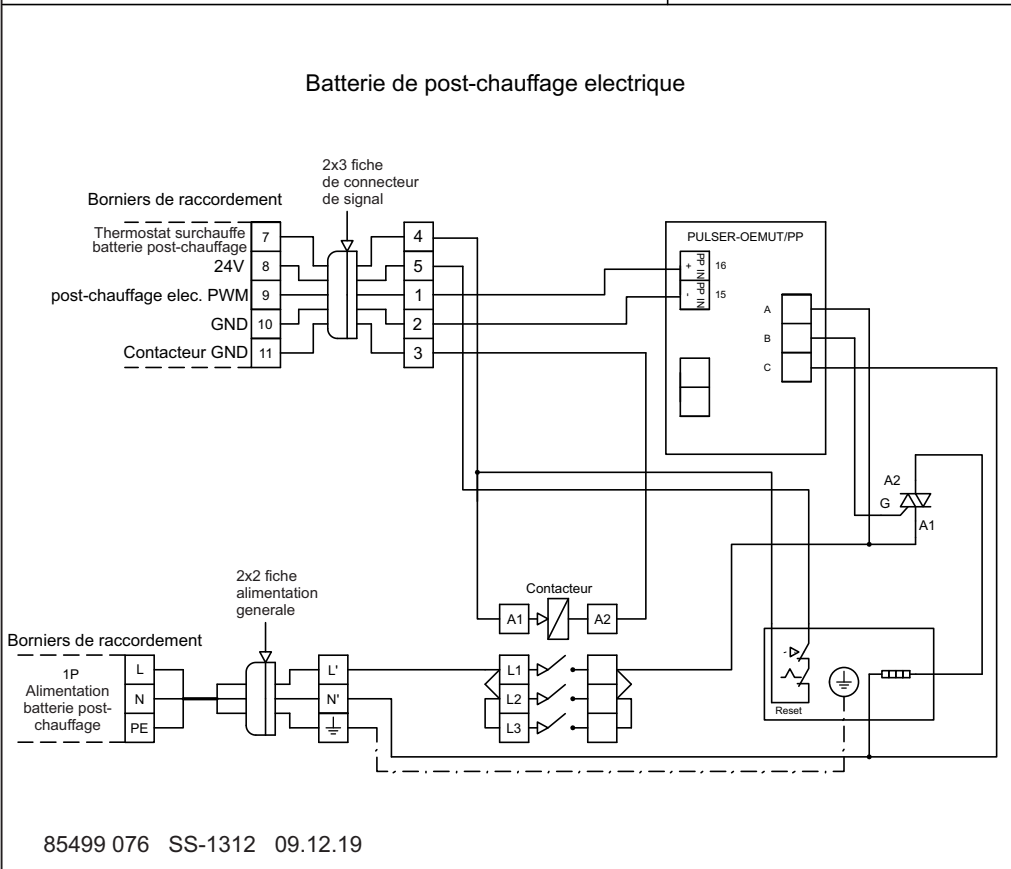
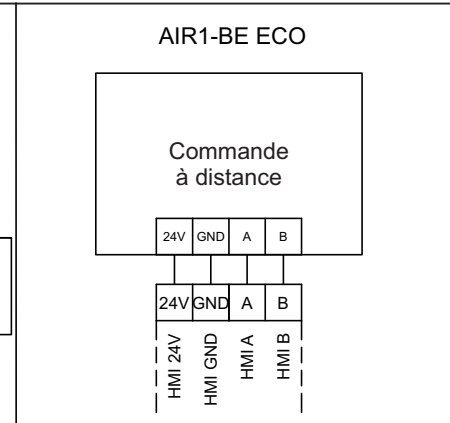
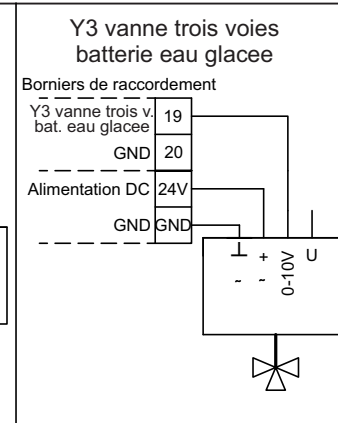
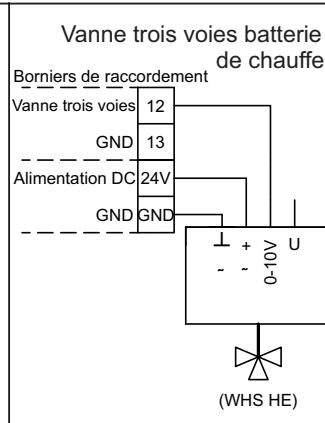
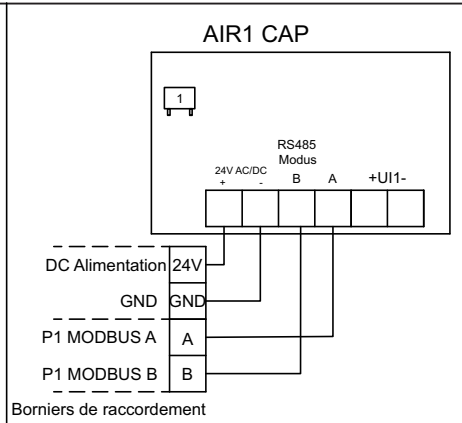
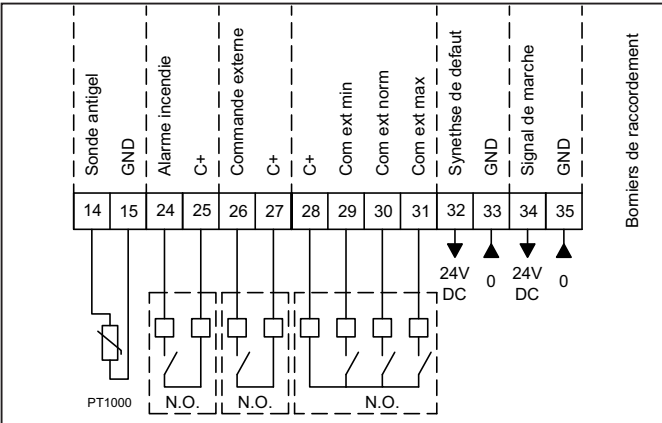

36-37: Sonde de qualité d'air 1 ou sonde temp. ambiante (Sortie température A2 sur KWL FTF)  
38-39: Sonde de qualité d'air 2  
40-41: Sonde de qualité d'air 3

